

8

7

6

5

4

3

2

1

TECHNICAL DATA	VA518
JAW WIDTH	4.95" (125.73 mm)
BASE LENGTH	18" (457.2 mm)
CLAMPING FORCE	5000 lbf @ 45 ft-lb (22.2 kN @ 61 Nm)
MAXIMUM TORQUE (LEADSCREW)	45 ft-lb (61 Nm)

VA518

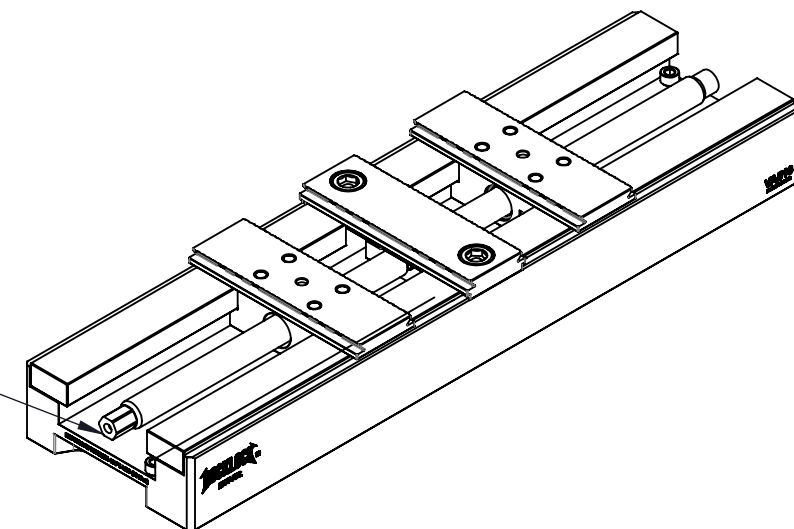

12mm HEX

8X FITS PS20F

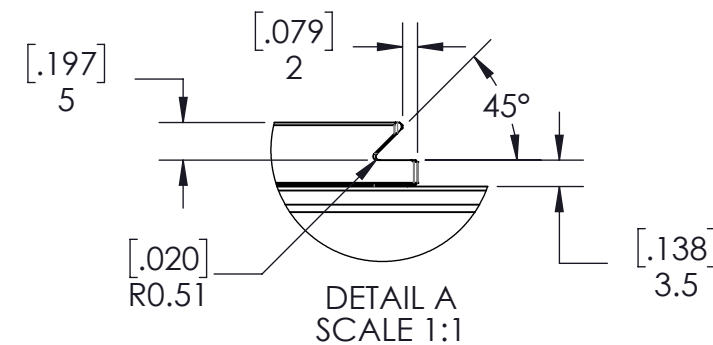
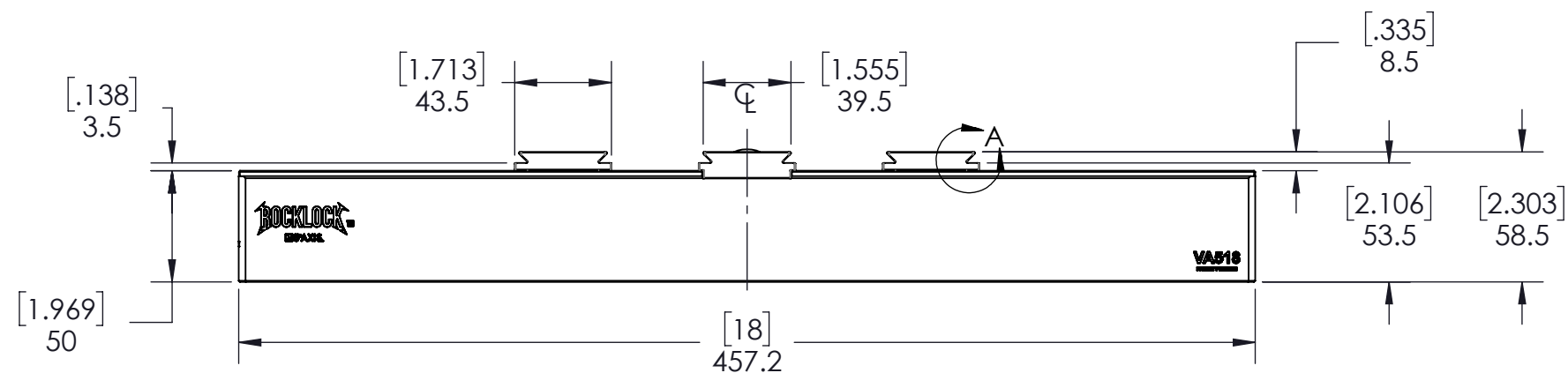
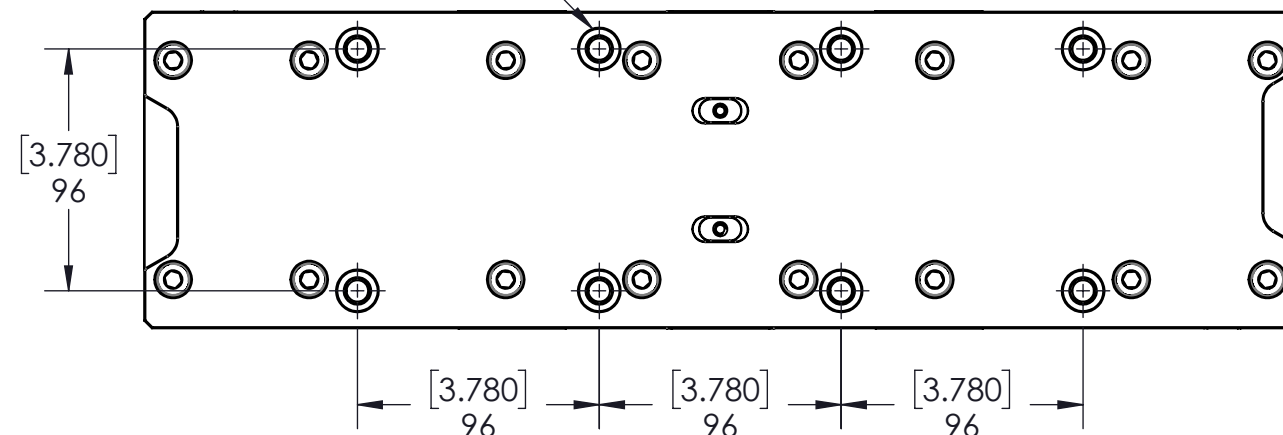
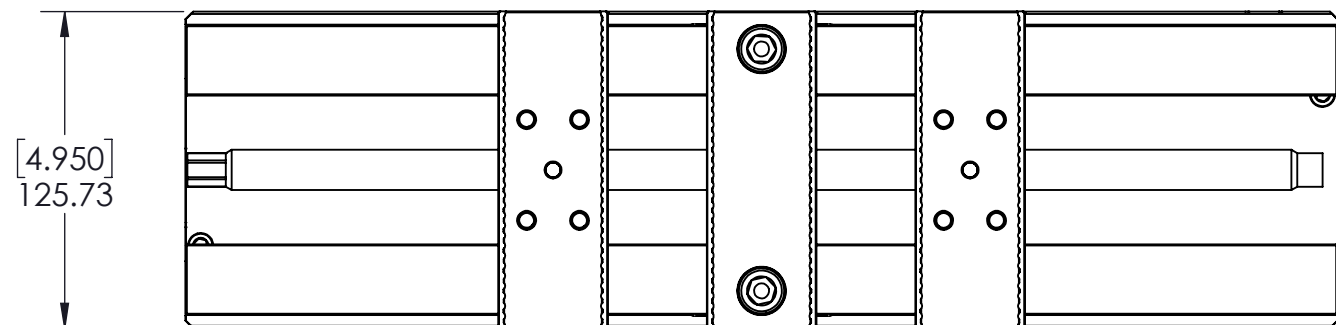

MILLIMETER <small>DRAWN IN ACCORDANCE WITH ASME Y14.5-2009</small> <small>WWW.5THAXIS.COM</small> <small>7140 ENGINEER ROAD SAN DIEGO, CA 92111</small> <small>P (858) 505-0432 F (858) 505-9344</small>	TOLERANCES <small>UNLESS OTHERWISE SPECIFIED</small> <small>ALL DIMENSIONS ARE FOR REFERENCE ONLY</small> <small>THIRD ANGLE PROJECTION</small>			
	<small>DESCRIPTION</small> <p style="text-align: center;">LITE VISE - 5X18</p>	<small>SIZE</small> <p style="text-align: center;">B</p>	<small>PART NO.</small> <p style="text-align: center;">VA518</p>	<small>REV</small> <p style="text-align: center;">B</p>
<small>DO NOT SCALE DRAWING</small>		<small>SCALE 1:3</small>	<small>WEIGHT: 25 lbs (11.4 kg)</small>	<small>SHEET 1 OF 4</small>

8

7

6

5

4

3

2

1

VA518

ITEM NO.	PART NUMBER	DESCRIPTION	QTY.
1	VA518-1	BASE, 5X18	1
2	VA56-2L	TRUCK, LEFT	1
3	VA56-2R	TRUCK, RIGHT	1
4	VA56-3B	BLOCK, BOTTOM	1
5	VA56-3T	BLOCK, TOP	1
6	VA518-4	SCREW, VA18, 16MM	1
7	VA513-5	LOW PROFILE STACKABLE CENTER BASE	1
8	VA518-6	LOCATING BLOCK	4
9	VA56-8	NUT	2
10	VA56-9	LOW PROFILE STACKABLE JAW BASE	2
11	VA56-10	WIPER SEAL	4
12	M12X35MM.LHSCS	LOW HEAD SOCKET CAP SCREW, M12X1.75X35MM	2
13	M8X025.SHCS	SOCKET HEAD CAP SCREW M8X1.25X25MM	8
14	M8X35MM.SHCS	SOCKET HEAD CAP SCREW M8X1.25X35MM	16
15	M6X6MM.SHCS	SOCKET HEAD CAP SCREW, M6X1X10MM	2
16	M5X20MM.SHCS	SOCKET HEAD CAP SCREW M5X.8X20MM	4
17	M16X30MM.DP	DOWEL PIN, M16X30MM	2
18	M6X10.DP	DOWEL PIN M6X10MM	2
19	HW.0520.FP	PIN, FRICTION, .520 STEPPED, BRASS	2
20	CS050-H2-S17	WAVE SPRING 17-4 C-TO-C W/SHIMS 0.50" OD K=115 LB/IN	2

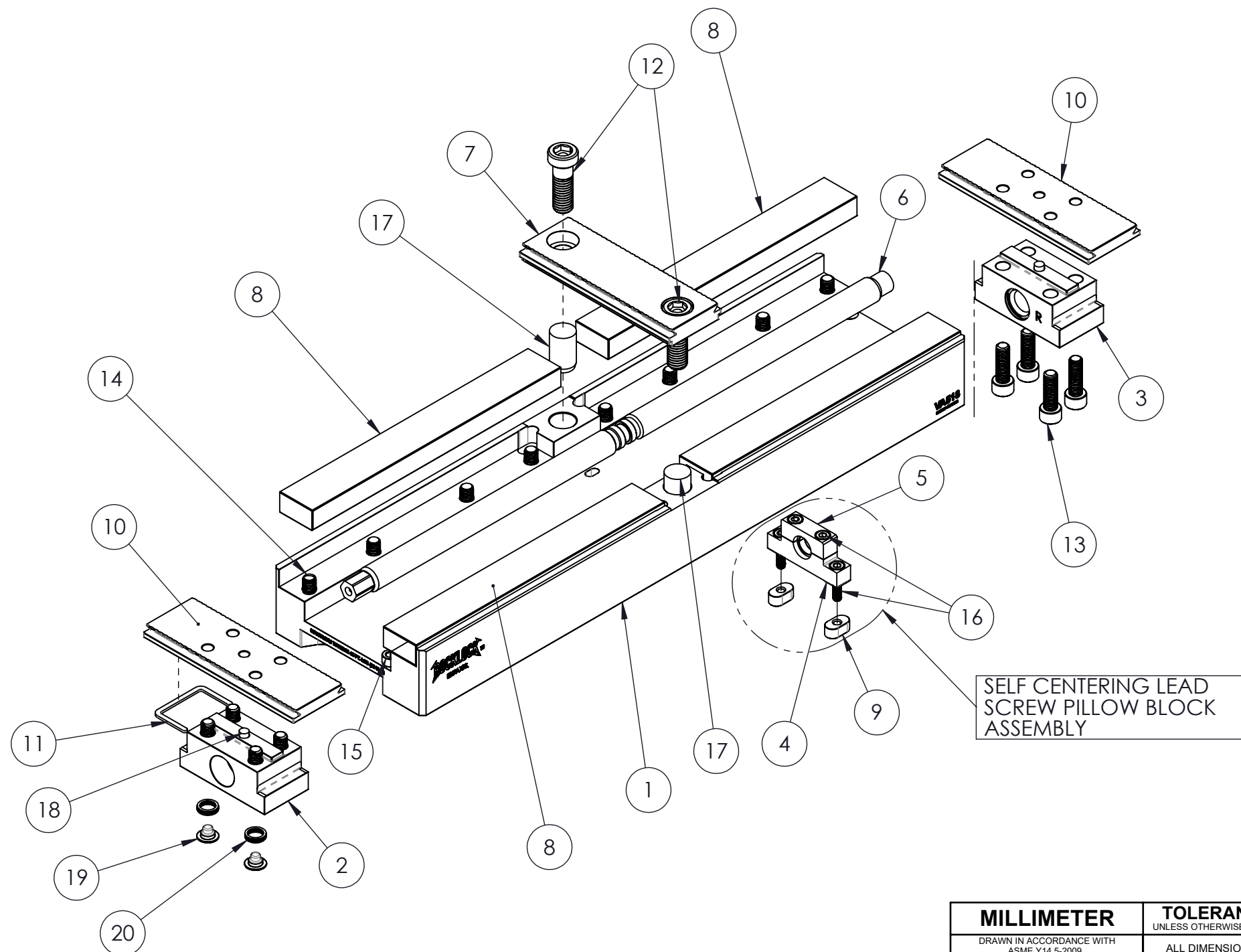

MILLIMETER <small>DRAWN IN ACCORDANCE WITH ASME Y14.5-2009</small>	TOLERANCES <small>UNLESS OTHERWISE SPECIFIED</small> <small>ALL DIMENSIONS ARE FOR REFERENCE ONLY</small> <small>THIRD ANGLE PROJECTION</small>								
		DESCRIPTION LITE VISE - 5X18							
<small>WWW.5THAXIS.COM</small> <small>7140 ENGINEER ROAD</small> <small>SAN DIEGO, CA 92111</small> <small>P (858) 505-0432</small> <small>F (858) 505-9344</small>		<table border="1"> <tr> <td> SIZE B </td> <td> PART NO. VA518 </td> <td> REV B </td> </tr> </table>	SIZE B	PART NO. VA518	REV B	<small>DO NOT SCALE DRAWING</small>	<small>SCALE 1:3</small>	<small>WEIGHT:</small>	<small>SHEET 2 OF 4</small>
SIZE B	PART NO. VA518	REV B							

8

7

6

5

4

3

2

1

NOTE: USING DOVETAIL ALLOWS VISE TO CLAMP LARGER PART.
BELOW CLAMPING RANGE ONLY SHOWS THE CAPABILITY OF THE GRIPPER TEETH.

VA518

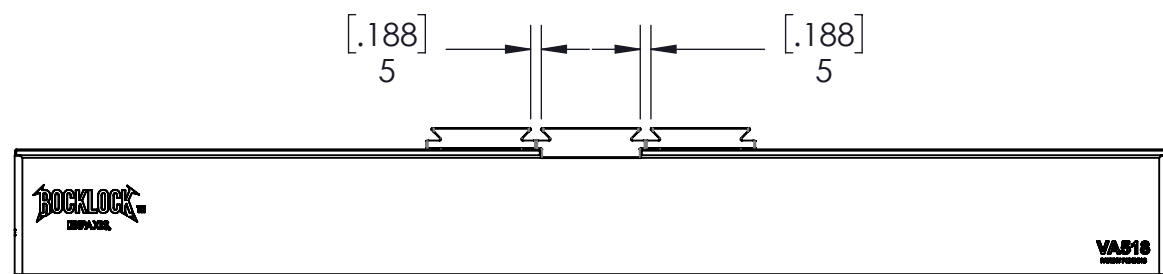

DOUBLE STATION (MINIMUM CLAMPING RANGE)

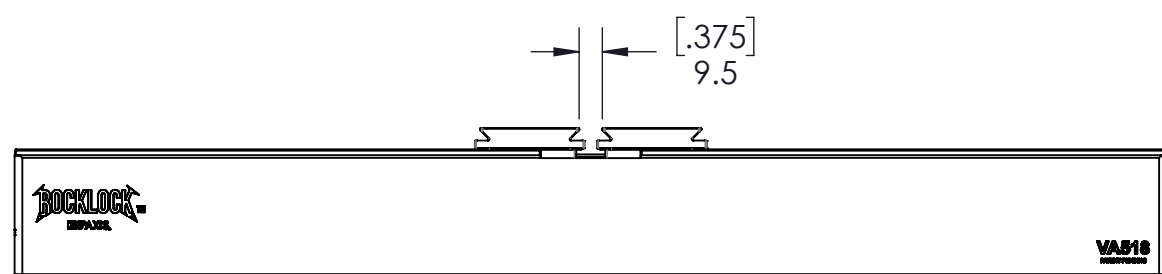

SELF CENTERING (MINIMUM CLAMPING RANGE)

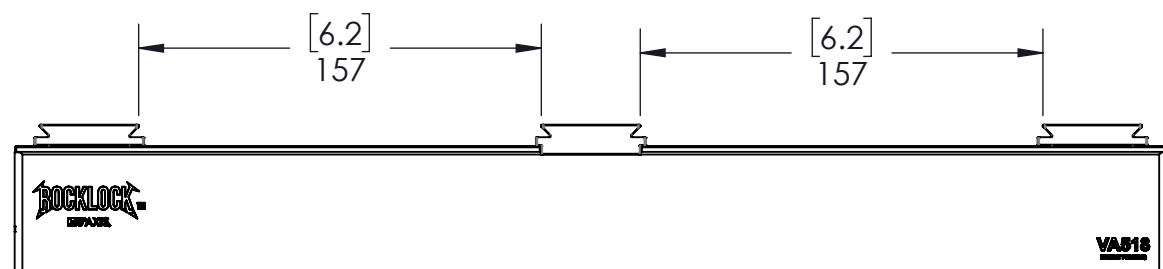

DOUBLE STATION (MAXIMUM CLAMPING RANGE)

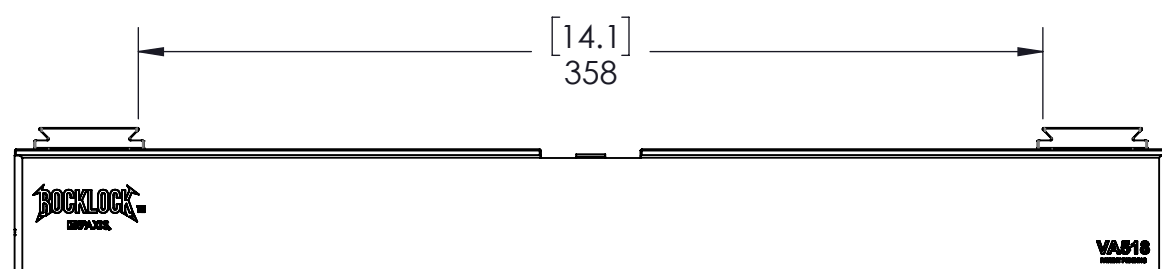

SELF CENTERING (MAXIMUM CLAMPING RANGE)

MILLIMETER <small>DRAWN IN ACCORDANCE WITH ASME Y14.5-2009</small> <small>WWW.5THAXIS.COM</small> <small>7140 ENGINEER ROAD SAN DIEGO, CA 92111</small> <small>P (858) 505-0432 F (858) 505-9344</small>	TOLERANCES <small>UNLESS OTHERWISE SPECIFIED</small> <small>ALL DIMENSIONS ARE FOR REFERENCE ONLY</small> <small>THIRD ANGLE PROJECTION</small>			
	<small>DESCRIPTION</small> <p style="text-align: center;">LITE VISE - 5X18</p>	<small>SIZE</small> <p style="text-align: center;">B</p>	<small>PART NO.</small> <p style="text-align: center;">VA518</p>	<small>REV</small> <p style="text-align: center;">B</p>
	<small>DO NOT SCALE DRAWING</small>	<small>SCALE 1:3</small>	<small>WEIGHT:</small>	<small>SHEET 3 OF 4</small>

8

7

6

5

4

3

2

1

8

7

6

5

4

3

2

1

NOTE: USING DOVETAIL ALLOWS VISE TO CLAMP LARGER PART.
BELOW CLAMPING RANGE ONLY SHOWS THE CAPABILITY OF THE GRIPPER TEETH.

VA518 SHOWN W/ OPTIONAL VA513-GJ-A

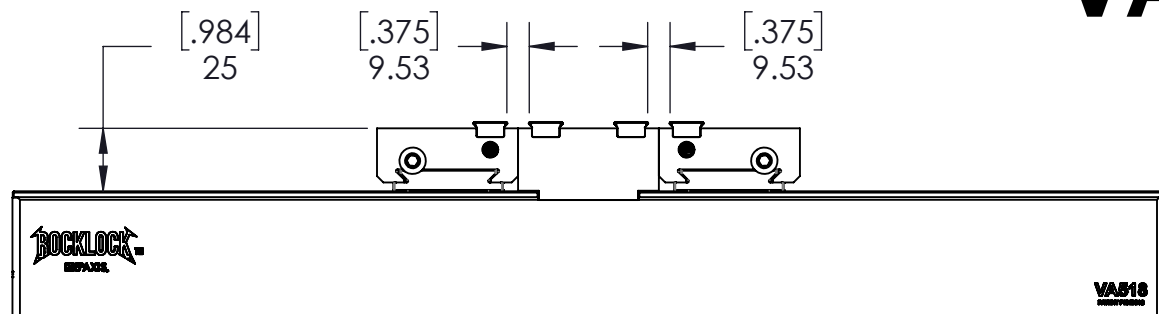

DOUBLE STATION (MINIMUM CLAMPING RANGE)

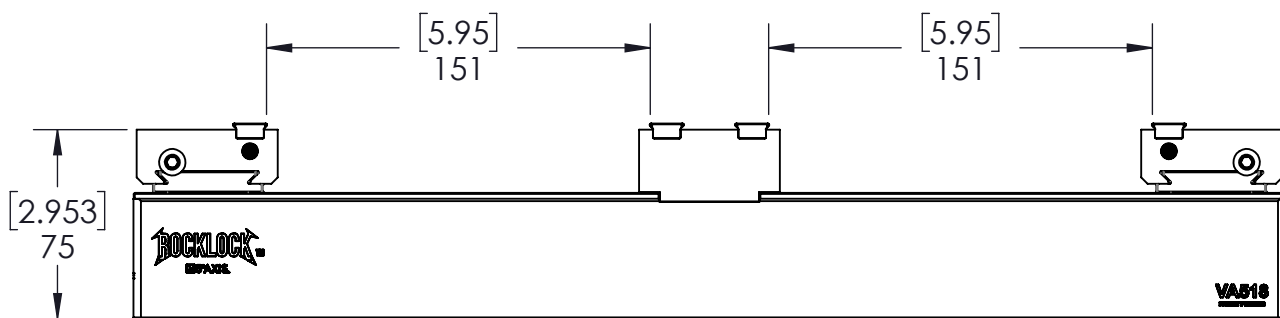

DOUBLE STATION (MAXIMUM CLAMPING RANGE)

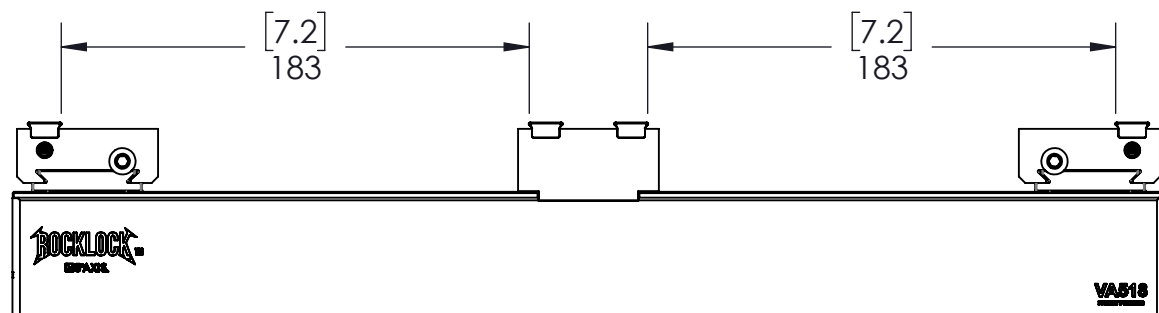

DOUBLE STATION W/JAWS REVERSED (MAXIMUM CLAMPING RANGE)

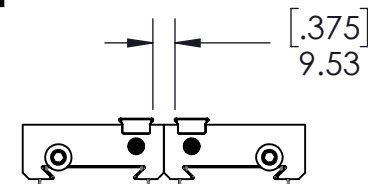

SELF CENTERING (MINIMUM CLAMPING RANGE)

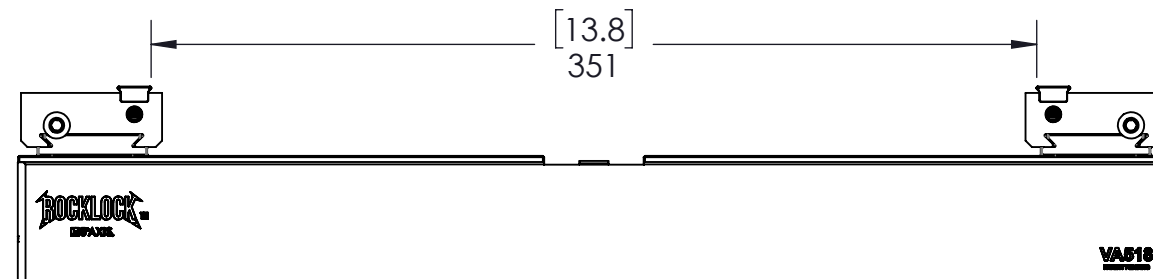

SELF CENTERING (MAXIMUM CLAMPING RANGE)

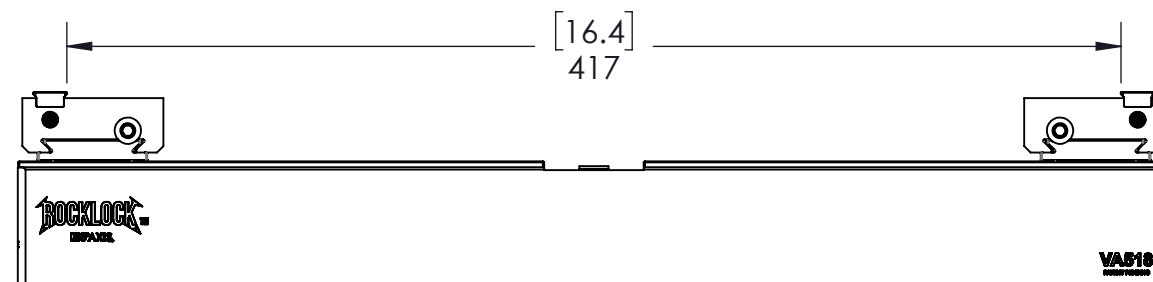

SELF CENTERING W/JAWS REVERSED (MAXIMUM CLAMPING RANGE)

MILLIMETER <small>DRAWN IN ACCORDANCE WITH ASME Y14.5-2009</small> <small>WWW.5THAXIS.COM</small> <small>7140 ENGINEER ROAD SAN DIEGO, CA 92111</small> <small>P (858) 505-0432 F (858) 505-9344</small>	TOLERANCES <small>UNLESS OTHERWISE SPECIFIED</small> <small>ALL DIMENSIONS ARE FOR REFERENCE ONLY</small> <small>THIRD ANGLE PROJECTION</small>			
	<small>DESCRIPTION</small> <p style="text-align: center;">LITE VISE - 5X18</p>	<small>SIZE</small> <p style="text-align: center;">B</p>	<small>PART NO.</small> <p style="text-align: center;">VA518</p>	<small>REV</small> <p style="text-align: center;">B</p>
<small>DO NOT SCALE DRAWING</small>		<small>SCALE 1:3</small>	<small>WEIGHT:</small>	<small>SHEET 4 OF 4</small>

8

7

6

5

4

3

2

1